

Pipette Tips

Sterile, autoclavable, crystal clear, and compatible with most pipette brands



Applications

- Accurate liquid transfer and dispensing
- General laboratory use

Quality Assurance Certification

Products are manufactured in accordance with international ISO 9001:2015 and ISO 13485 standards. Free from R-NASE, D-NASE, and pyrogens, and meet USP Class VI requirements.

Technical Specifications

Material Type	Polypropylene (PP).
RNase/DNase	RNase/DNase free.
Pyrogens	Pyrogen free.
Surface Properties	Highly hydrophobic.
Sterilization	E-beam or ionizing radiation.
Autoclavability	Tips and boxes are autoclavable.
Chemical Compatibility	Material withstands organic solvents.
Shelf Life	5-year shelf life from manufacturing date
Sterility Condition (tips in bag)	Non-sterile

Pipette Tips

Key Advantages

- Hydrophobic Anti-Contamination Filter. Filtered tips feature a highly hydrophobic porous barrier that blocks aerosols and helps prevent cross-contamination between samples.
- Crystal Clear Transparency. Made from ultra-clear polypropylene for easy viewing of contents.
- Universal Compatibility. Designed to fit most pipettes on the market.

Technical Drawing

Universal Pipette Tips

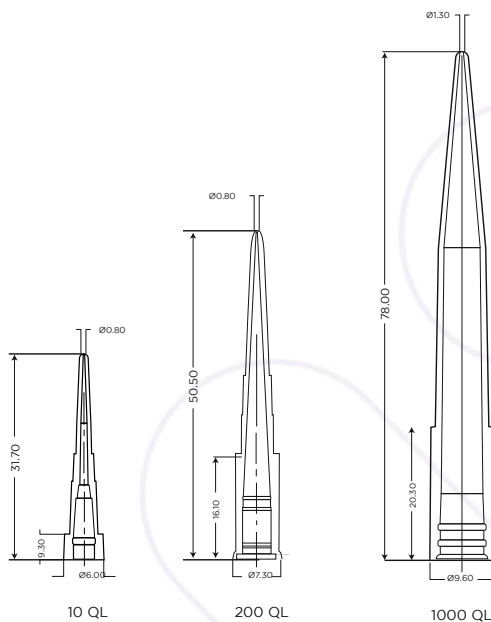

Universal Pipette Tips with Filter

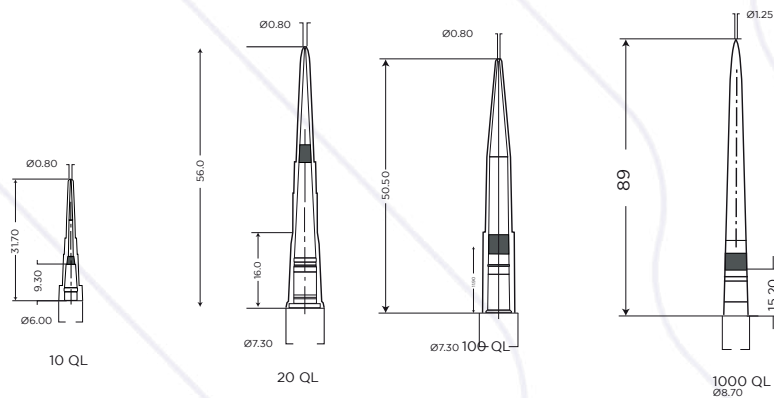

Pipette Tips

Ordering Information

Universal Pipette Tips

Code	Description	Package Presentation
R304016	Universal 1000 Ql pipette tips, extra-long, sterile, rack-packed	Rack of 96 tips
R304006	Universal 1000 Ql pipette tips, extra-long, clear, no filter, non-sterile, bagged	Pack of 500 tips
R302106	Universal 200 Ql pipette tips, yellow, bulk-packed, non-sterile	Bag of 1000 tips
R302116	Universal 200 Ql pipette tips, yellow, sterile, rack-packed	Rack of 96 tips

Universal Pipette Tips with Filter

Code	Description	Package Presentation
R313012	Universal pipette tips with filter, 1000 Ql, extra-long, rack-packed, sterile	Rack of 96 tips
R314036	Universal pipette tips, 10 Ql, rack-packed, sterile, DNase- and RNase-free, clear, with filter	Rack of 96 tips
R310012	Universal pipette tips, 20 Ql, rack-packed, sterile, DNase- and RNase-free, clear, with filter	Rack of 96 tips
R316012	Universal pipette tips with filter, 100 Ql, rack-packed, sterile	Rack of 96 tips

Storage

- Store at (25±5)°C.
- Keep in a dry place with relative humidity below 70%.
- Do not open the original sealed packaging until ready to use.
- Avoid exposure to harsh chemicals or extreme temperatures that could damage the polypropylene material.